

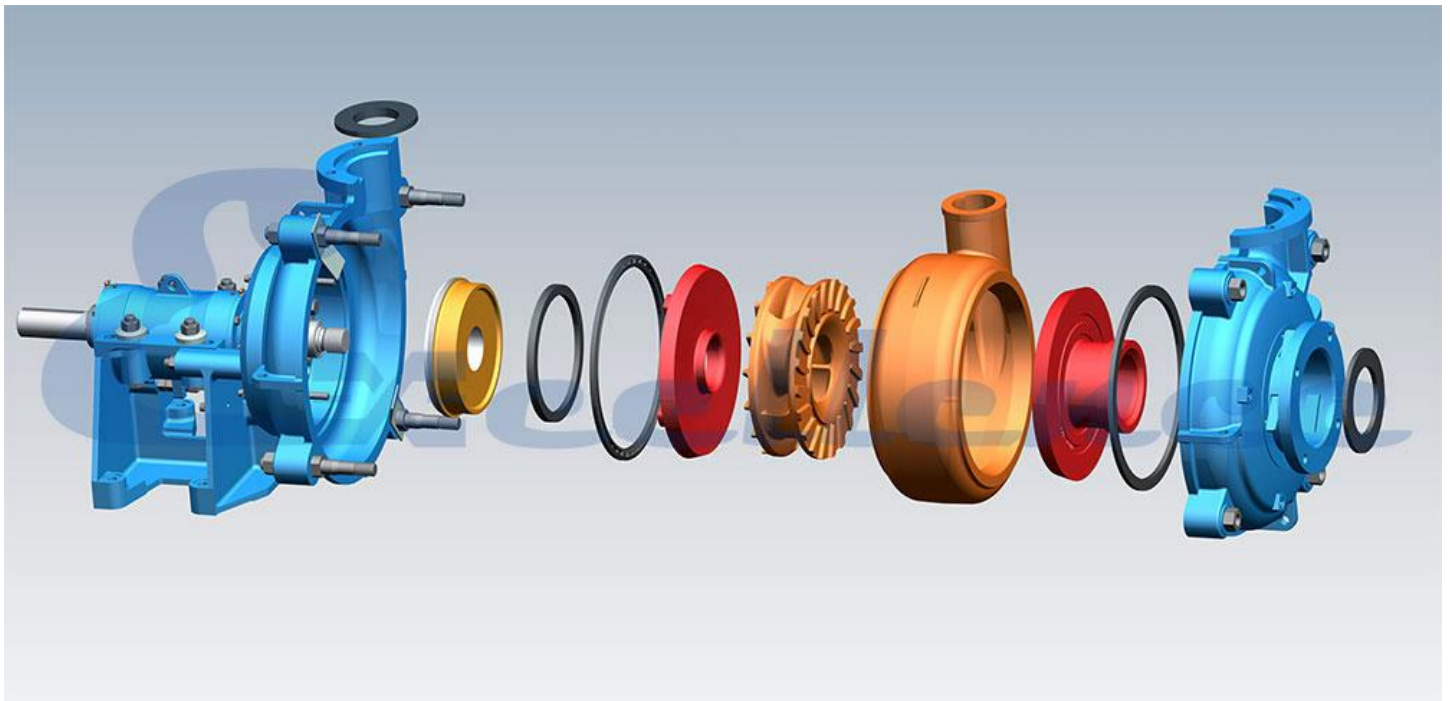

Designed for handling strong abrasive and high concentration slurries, EHM series slurry pumps are cantilevered heavy duty slurry pumps with metal liner. With thick wear parts and heavy duty support, EHM series could run in series in the allowable range of pump working pressure. This series have become the first choice of various working conditions and clients from home and abroad think highly of EHM series' excellent performance.



- Cylindrical structure of bearing assembly: convenient to adjust the space between impeller and throatbush and can be removed completely;
- Interchangeable anti-abrasive wet parts made of high-chrome alloys;
- The discharge direction can be oriented to any eight positions at the interval of 45 degrees;
- It can be installed in multistage series to meet the delivery for long distance;
- Various drive types: DC(direct connection), V-belt drive, gear box reducer, hydraulic couplings, VFD, SCR control, etc;
- The shaft seal can be packing seal, expeller seal or mechanical seal;
- High efficiency, long lifetime and easy maintenance.

## ❖ Structure

### Series EHM structural drawing:

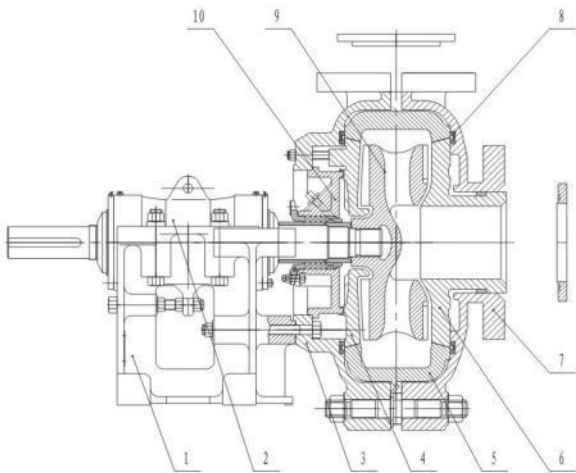

- |                             |                           |
|-----------------------------|---------------------------|
| 1. Frame                    | 6. Throatbush             |
| 2. Bearing assembly         | 7. Cover plate            |
| 3. Frame plate              | 8. Volute liner seal ring |
| 4. Frame plate liner insert | 9. Impeller               |
| 5. Volute liner             | 10. Stuffing box          |

Note: this is the basic drawing of structure. There would be some differences up to varied discharge size.



EHM-12ST

### Bearing Assembly

Convenient to adjust the space between impeller and front liner and can be removed completely;

- Lubricated by grease;
- Easy maintenance;

### Shaft Seal

There are three standard shaft seal methods:

- Packing seal: it is the lowest in cost.
- Expeller seal: it is most commonly used.
- Mechanical seal: it has best seal effect, but high in cost and has strict requirement of flush water.

### Material

The wet parts material for standard EHM series pump is high-chrome alloy. This kind of material is wear resistant and has excellent performance under erosive conditions.

- KmTBCr27: hard carbides within its microstructure provides strong wear resistance
- KmTBCr28: its hardness is 430 in Brinell and suitable for corrosive applications where pH is below 4.
- KmTBCr35: its hardness is 450 in Brinell and has much improved corrosion resistance.

## ❖ Performance Chart

Model	Allowable Max. Power P(Kw)	Clear Water Performance						Impeller
		Capacity Q		Head H(m)	Speed n(r/min)	Top Efficiency η%	NPSH(m)	Impeller Diameter D(mm)
		m <sup>3</sup> /h	l/s					
EHM-1B	15	12.6-28.8	3.5-8	6-68	1200-3800	40	2-4	152
EHM-1.5B	15	32.4-72	9-20	6-58	1200-3200	45	3.5-8	184
EHM-2C	30	39.6-86.4	11-24	12-64	1300-2700	55	4-6	214
EHM-3C	30	86.4-198	24-25	9-52	1000-2200	71	4-6	245
EHM-3D	60							
EHM-4D	60	162-360	45-100	12-56	800-1550	65	5-8	365
EHM-4E	120							
EHM-6E	120	360-828	100-230	10-61	500-1140	72	2-9	510
EHM-6R	300							
EHM-8ST	560	612-1368	170-380	11-61	400-850	71	4-10	686
EHM-10ST	560	936-1980	260-550	7-68	300-800	82	6	762
EHM-12ST	560	1260-2772	350-770	13-63	300-600	77	3-10	965
EHM-14TU	1200	1368-3060	380-850	11-63	250-550	79	4-10	1067

## ❖ Application

Series EHM slurry pumps are widely used in mining, coal washing, power plant, metallurgy, petrochemical, building material, dredging, and other industrial fields, etc.

### Typical Application:

- Iron Ore Dressing Plant
- Copper Concentration Plant
- Gold Mine Concentration Plant
- Molybdenum Concentration Plant
- Potash Fertilizer Plant
- Other Mineral Processing Plants
- Alumina Industry
- Coal Washery
- Power Plant
- Sand Excavation
- Building Material Industry
- Chemical Industry
- Other industries



*EHM-4D in Sand Excavation*

*In Europe*



*EHM-8ST in Mid-East*



*EHM-10ST in Gold Processing Plant in China*



*EHM-2C in Copper Concentration Plant in Africa*

**Headquarter:**

Add: No.368, Xinshi North Road, Shijiazhuang, Hebei, China 050091.

**Beijing Branch:**

Add: No.78, East 4th Ring Middle Road, Beijing, China 100124.

Tel: +86-10-59626498

Fax: +86-10-59626499

For inquiries, please send your emails to [sales@excellencepump.com](mailto:sales@excellencepump.com)

For customer service, please send your emails to [service@excellencepump.com](mailto:service@excellencepump.com)